



Coral Sofa



Finishes of the above picture



Fabric
Wool Bouclé
Col. 03 Linen



Wood
Ashwood with
acetic finish

Forme generose ed abbondanti per una serie di imbottiti il cui disegno riprende la morbidezza di una nuvola. La struttura monolitica non pesa all'occhio, grazie all'inusuale partizione degli elementi che compongono le forme: schienale, braccioli, seduta, che sembrano tra loro incastonati come elementi naturali plasmati dal tempo.

Divano 3 posti con imbottitura realizzata in gomme biologiche, cuffia in ovatta naturale e cinghie in juta. Rivestimento non sfoderabile. Base in frassino massello ecosostenibile non selezionato, con finitura acetica.

Generous and abundant shapes for a series of upholstered furniture items with cloud-like, accommodating design. The monolithic structure is pleasant to eyes, thanks to the unusual partitioning of the individual elements that make up the whole: backrest, armrests and seat, which seem to fit together like natural elements fashioned by time.

Three-seater sofa with cushioning made of biological polyurethane covered with natural wadding, and jute webbing. Unremovable covering. Wood basement in ashwood with acetic finish.

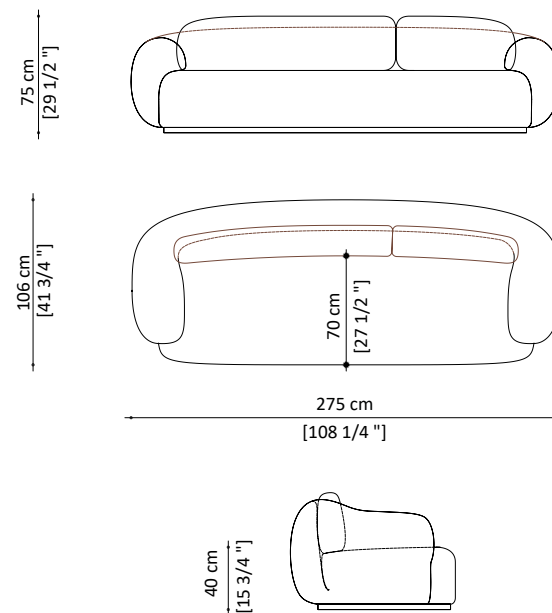

BLENDED LINEN / IPA LINEN | SED.CORA.100.SUP

Solid wood basement
Covered in blended linen or linen fabric

BOUCLE' WOOL / CHENILLE | SED.CORA.100.DEL

Solid wood basement
Covered in bouclé wool fabric or chenille fabric

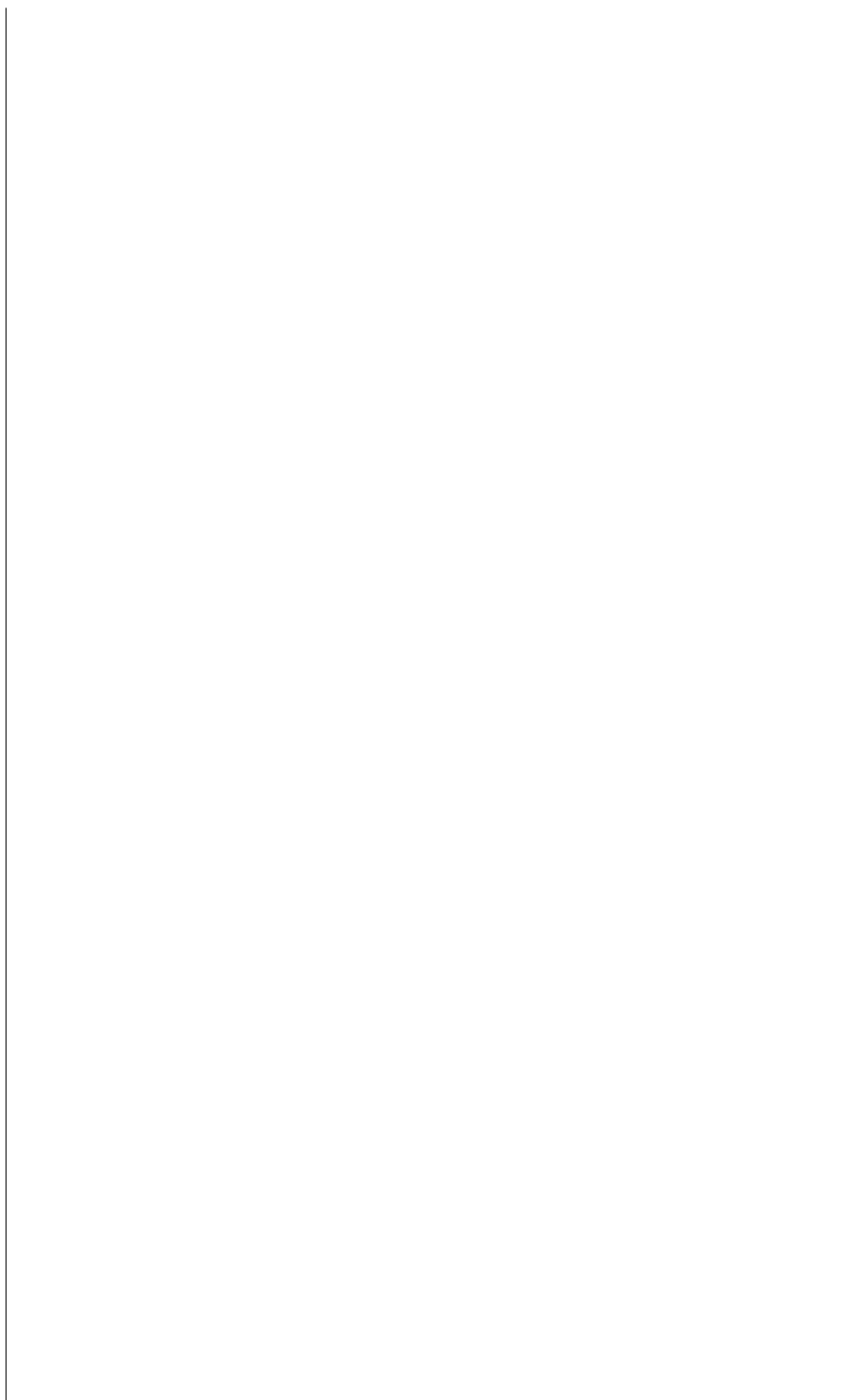

Coral Armchair



Finishes of the above picture



Fabric
Wool Bouclé
Col. 03 Linen



Wood
Ashwood with
acetic finish

Forme generose ed abbondanti per una serie di imbottiti il cui disegno riprende la morbidezza di una nuvola. La struttura monolitica non pesa all'occhio, grazie all'inusuale partizione degli elementi che compongono le forme: schienale, braccioli, seduta, che sembrano tra loro incastonati come elementi naturali plasmati dal tempo.

Poltrona compatta, con imbottitura realizzata in gomme biologiche, cuffia in ovatta naturale e cinghie in juta. Rivestimento non sfoderabile. Base in frassino massello ecosostenibile non selezionato, con finitura acetica.

Generous and abundant shapes for a series of upholstered furniture items with cloud-like, accommodating design. The monolithic structure is pleasant to eyes, thanks to the unusual partitioning of the individual elements that make up the whole: backrest, armrests and seat, which seem to fit together like natural elements fashioned by time.

Three-seater sofa with cushioning made of biological polyurethane covered with natural wadding, and jute webbing. Unremovable covering. Wood basement in ashwood with acetic finish.

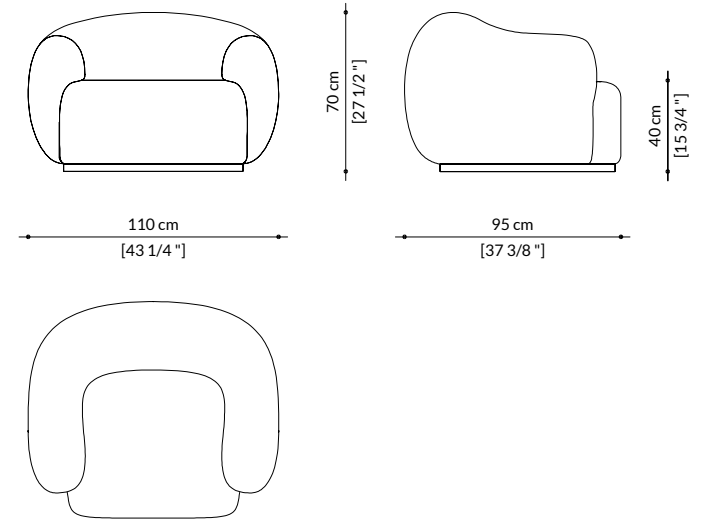

BLENDED LINEN / IPA LINEN | SED.CORA.200.SUP

Solid ashwood basement with acetic finish
Covered in blended linen or linen fabric

BOUCLE' WOOL / CHENILLE | SED.CORA.200.DEL

Solid wood basement
Covered in bouclé wool fabric or chenille fabric



PAOLO CASTELLI

BOLOGNA
Headquarter

MILAN
Showroom

PARIS
Showroom

CARRARA
Marine Division

HEADQUARTER VIA 1° MAGGIO, 93 | 40064 OZZANO DELL'EMILIA | BOLOGNA - ITALY | TEL. +39 051 4695511 | info@paolocastellispa.com | www.paolocastelli.com