

# PASTILLA

design: Patricia Urquiola / 2000

# KUNDALINI

Lampada da parete, struttura in metallo verniciato bianco. Struttura in vetro pressato e acidato.

Wall lamp, structure in white painted metal. Diffuser in pressed acid-etched glass.



## CERTIFICAZIONI - CERTIFICATIONS



Apparecchio di classe I  
Product in class I

IP20

Apparecchio per uso interno  
Product for indoor use



Apparecchio conforme alla direttiva europea 2006/95/EC  
Product in conformity with the European directive 2006/95/EC



Apparecchio di illuminazione da smaltire secondo la direttiva EU 2002/96/EC  
This lamp must be disposed in conformity with the EU directive 2002/96/EC

## DIMENSIONI - DIMENSIONS

Side view

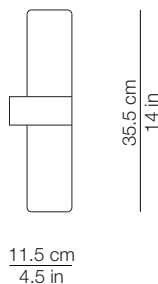

Top view



## IMBALLO - PACKAGING

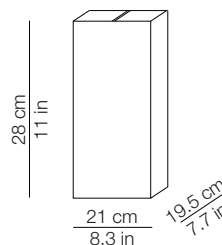

Volume: 0.011 m<sup>3</sup> / 0.401 ft<sup>3</sup>  
Gross weight: 2.06 kg / 4.53 lbs

## MATERIALI E FINITURE - MATERIALS AND FINISHINGS

diffusore  
diffuser

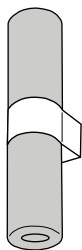

vetro pressato e acidato  
pressed and acid-etched glass



bianco opalino -  
white opal

bianco - white



struttura  
structure

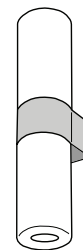

struttura in metallo verniciato  
painted metal structure

## INFORMAZIONI AGGIUNTIVE - FURTHER INFORMATION

230V  
or  
120V

Alimentazione  
Feeding



Lampadine - Bulbs  
2 x max42W E14 (E12 US) - Halogen  
or 2 x max12W E14 (E12 US) - Fluorescent  
or 2 x 6W E14 (E12 US) - Led



Energy efficiency class from A+ to E

Lampada da parete  
Wall lamp



Lampada da soffitto  
Ceiling lamp



# KUNDALINI

---

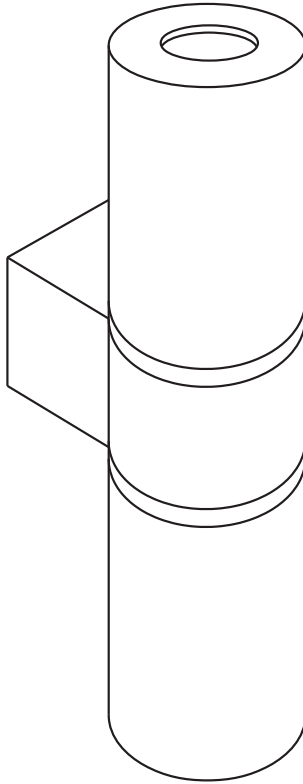

**PASTILLA**

Patricia Urquiola, 2000

**Istruzioni di montaggio  
Assembly instructions  
Montage-anleitung  
Instrucciones de montaje  
Instrucciones de montaje**

---



Classe I-Class I-Schutzklasse I-Classe I-Clase I



**IT**-Apparecchio idoneo ad essere installato su superfici normalmente infiammabili.

**EN**-Appliance suitable for installation on normally inflammable surfaces.

**DE**-Gerät, welches auf Oberflächen installiert werden kann, die normalerweise entzündbar sind.

**FR**-Appareil destiné à être installé des surfaces normalement inflammables.

**ES**-Aparato apto para ser instalado sobre superficies normalmente inflamables.



**IT**-Attesta la conformità del prodotto alle disposizioni delle direttive comunitarie.

**EN**-It certifies the conformity of the product to the european community low voltage directive.

**DE**-Das Zeichen bestätigt die Übereinstimmung des Produkts mit den Bestimmungen der EU-Richtlinien.

**FR**-Il atteste la conformité du produit aux dispositions des directives communautaires.

**ES**-Certifica la conformidad del producto a las disposiciones de las normas de la comunidad.

**IT**-Il simbolo RAEE utilizzato per questo prodotto indica che quest'ultimo non può essere trattato come rifiuto domestico.

**EN**-The use of the WEEE symbol indicates that this product may not be treated as household waste.

**DE**-Durch Verwendung des WEEE-Symbols weisen wir darauf hin, dass dieses Produkt nicht als normaler Haushaltsmüll behandelt werden darf.

**FR**-L'utilisation du symbole WEEE indique que ce produit ne peut pas être traité comme déchet domestique.

**ES**-El símbolo RAEE en un producto indica que éste no se puede eliminar como cualquier otra basura.



## ATTENZIONE

La sicurezza dell'apparecchio è garantita con l'uso appropriato delle seguenti istruzioni, pertanto è necessario conservarle. Togliere sempre la tensione prima di operare sull'apparecchio.

Per pulire la lampada non usare mai prodotti abrasivi o detersivi aggressivi.

Se il cavo esterno di questo apparecchio viene danneggiato, deve essere sostituito esclusivamente dal costruttore, dal suo servizio assistenza, o da personale qualificato equivalente, al fine di evitare pericoli.

Kundalini non effettuerà nessuna sostituzione se non dopo aver accertato la natura del difetto.

## WARNING

The safety is guaranteed by the appropriate use of the following instructions, so you must keep them.

Always disconnect the main voltage before working on the appliance.

Never use abrasive products or aggressive detergents for cleaning the lamp.

If the external cable of this appliance is damaged, it must be replaced by the manufacturer, its after sales service or other equivalent qualified person only in order to avoid any danger.

Kundalini will not provide a replacement until the nature of defect has been determined.

## ACHTUNG

Die Sicherheit dieses Artikels wird nur durch die strikte Befolgung der nachfolgenden Betriebsanleitung gewährleistet. Bitte heben Sie diese unbedingt auf.

Vor allen Arbeiten ziehen Sie bitte den Stecker aus der Dose.

Für die Reinigung der Lampe niemals Schleifmittel oder aggressive Reinigungsmittel verwenden

Sollte das Außenkabel der Lampe beschädigt werden, ist es ausschließlich vom Service-Dienst des Herstellers oder gleichwertigen, qualifiziertem Personal auszutauschen, um somit Gefahren zu vermeiden.

Kundalini leistet grundsätzlich erst nach einer gründlichen Überprüfung Ersatz.

## ATTENTION

La sûreté de l'appareil n'est garantie qu'en suivant scrupuleusement les instructions ci-après. Il est donc nécessaire de les conserver.

Isoler l'appareil du secteur avant toute manipulation.

Pour nettoyer la lampe, ne jamais utiliser de produits abrasifs ou de nettoyeurs agressifs.

Si le câble externe de cet appareil est endommagé, il doit être remplacé uniquement par les soins du constructeur, par son service après-vente ou bien par le personnel équivalent, et ce afin d'éviter tout danger.

Kundalini ne remplacera aucun appareil sans en avoir pu vérifier le défaut.

## ATENCIÓN

La seguridad del aparato está garantizada sólo con el uso apropiado de las instrucciones siguientes, por lo tanto es necesario atenderlas puntualmente.

Desconectar siempre la alimentación antes de trabajar en el aparato.

Nunca utilice productos abrasivos o detergentes agresivos para limpiar la lámpara.

Si el cable externo de este aparato se deteriora será necesario sustituirlo; la sustitución podrá efectuarla exclusivamente el fabricante, su servicio de asistencia o personal cualificado equivalente para evitar peligros.

Kundalini no efectuará sustitución alguna hasta después de haber verificado la naturaleza del defecto.

---

BOX

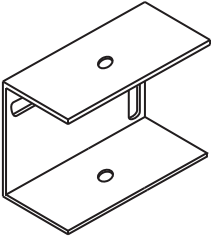

1x

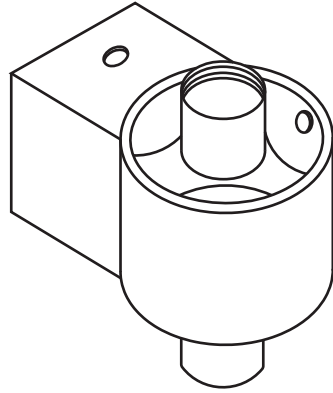

1x

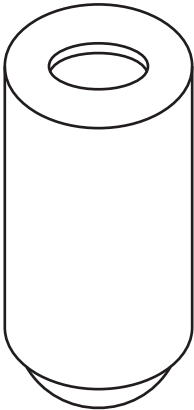

2x

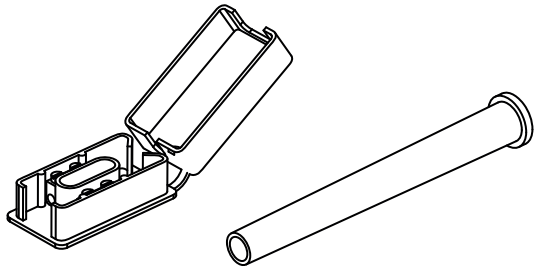

1x

---

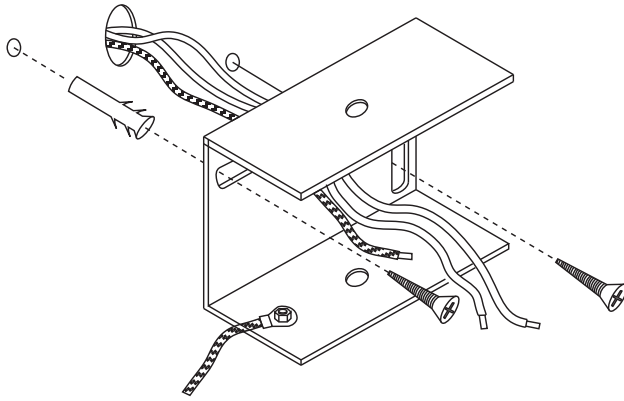

1

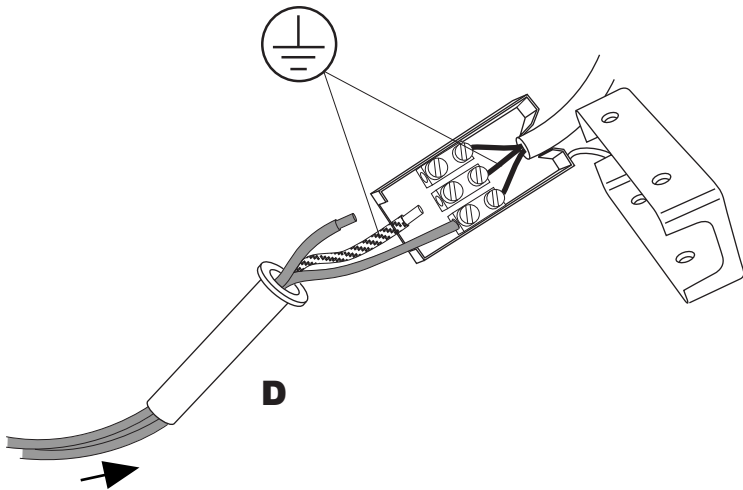

2

---

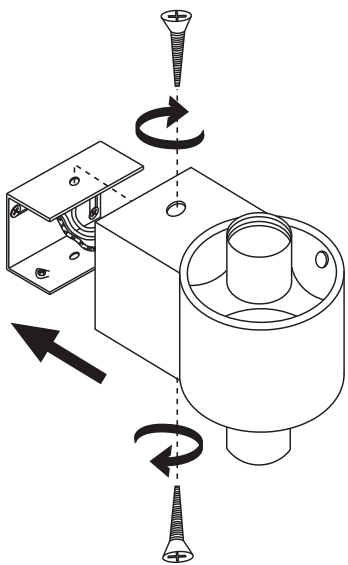

3

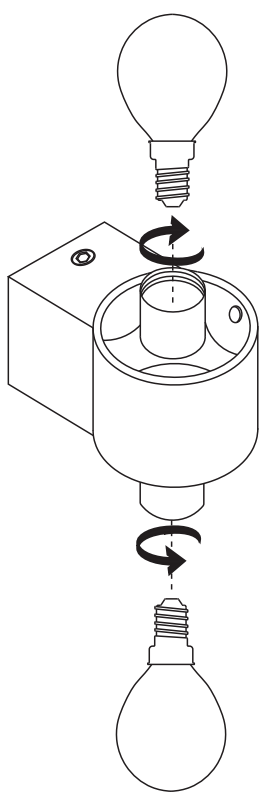

4

---

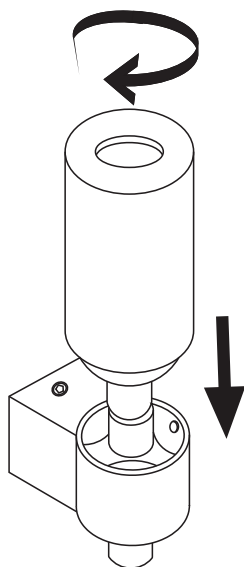

5

## ISTRUZIONI DI MONTAGGIO

Togliere la tensione di rete. Far passare i cavi di rete attraverso il foro centrale del rosone e fissare a muro la struttura elettrica utilizzando viti con controviti ad espansione idonee alle caratteristiche del muro - **Fig.1** -. Cablare i cavi di rete alla morsettiere, notando che il cavo di terra deve essere cablato al morsetto contrassegnato dal simbolo - **Fig.2** -. Fissare la struttura della lampada avvitando le due viti come in - **Fig.3** -. Montare le lampadine maneggiandole con cura - **Fig.4** -. Applicare i vetri diffusori operando una piccola rotazione fino al loro serraggio alla struttura - **Fig.5** -. Ripristinare la tensione di rete.

## ASSEMBLY INSTRUCTIONS

Turn off electricity. Pass the supply cable through the hole of the canopy and fix it with appropriate expansion screws to the wall - **Fig.1** -. Fix the cables to the connector, making sure that the earth cable must be fixed to the clip marked as - **Fig.2** -. Fix the structure with the screws supplied - **Fig.3** -. Set up the bulbs - **Fig.4** -. Place the glass diffusers on the structure by turning them until they are safely closed - **Fig.5** -. Turn on the main voltage.

## MONTAGE-ANLEITUNG

Die Netzspannung abschalten. Die Netzkabel durch das Loch in der Mitte der Rosette führen und die elektrische Konstruktion an der Wand befestigen, dabei Schrauben mit Spreizmuttern verwenden, die für die jeweilige Wand geeignet sind - **Abb.1** -. Die Netzkabel mit der Klemme verkabeln, dabei beachten, dass das Erdungskabel mit der durch das Symbol gekennzeichneten Klemme verkabelt werden muss - **Abb.2** -. Die Lampenkonstruktion befestigen, indem die beiden Schrauben festgeschraubt werden wie in - **Abb.3** -. Die Glühbirnen vorsichtig einsetzen - **Abb.4** -. Die Diffusorscheiben einsetzen, dabei eine leichte Drehung ausführen, bis sie fest in der Konstruktion sitzen - **Abb.5** -. Die Netzspannung wiederherstellen.

---

## INSTRUCTIONS DE MONTAGE

Couper le courant. Faire passer les fils électriques à travers le trou central de la rosace et fixer la structure électrique au mur en utilisant des vis et des chevilles à expansion adaptées aux caractéristiques du mur - **Fig.1** -. Raccorder les fils électriques aux bornes, en faisant attention à ce que le fil de terre soit raccordé à la borne indiquée par le symbole - **Fig.2** -. Fixer la structure de la lampe en vissant les deux vis comme dans la - **Fig.3** -. Placer les ampoules en les manipulant avec précaution - **Fig.4** -. Appliquer les verres diffuseurs en effectuant une petite rotation jusqu'à leur serrage à la structure - **Fig.5** -. Rebrancher le courant.

## INSTRUCCIONES DE MONTAJE

Quitar la tensión de red. Meter los cables de red a través del orificio central de la caja y fijarla en el muro o el techo utilizando cuatro tornillos con tacos de expansión apropiados para las características del muro - **Fig.1** -. Conectar los cables al borne, advirtiéndole que el cable de tierra se tiene que conectar a la bornera señalada por el símbolo - **Fig.2** -. Fijar la estructura de la lámpara enroscando los dos tornillos como en **Fig.3** -. Montar las bombillas manejándolas con cuidado - **Fig.4** -. Aplicar los cristales difusores realizando un pequeño giro hasta que queden fijados a la estructura - **Fig.5** -. Restablecer la tensión de red.

### LAMPADINE-BULBS-LEUCHTENMITTEL-AMPOULES-BOMBILLAS:

halogen 2x42W E14 (E12US) clear



or fluo 2x12W E14 (E12US)



or led 2x6W E14 (E12US)



Energy efficiency class from A++ to E

### ALIMENTAZIONE-FEEDING-SPANNUNG-ALIMENTATION-TENSION DE RED:

220-240V



## **KUNDALINI SRL**

I-20090 Trezzano sul Naviglio - Milano

Viale Leonardo da Vinci, 277

phone +39 02 3653 8950

fax +39 02 3653 8964

[www.kundalini.it](http://www.kundalini.it)

[info@kundalini.it](mailto:info@kundalini.it)

JOIN OUR COMMUNITY



[kundalini.lighting](https://www.facebook.com/kundalini.lighting)



[kundalini\\_lighting](https://www.instagram.com/kundalini_lighting)

---